

SECTION A-A

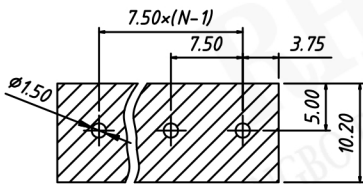

PCB LAYOUT



Material

Screw: M2.5, Steel, Zn plated
 Cage: Iron, Nickel plated
 Pin header: Brass, Tin plated
 Housing: PA66, UL94V-0

Electrical

Rated voltage: 300V
 Rated current: 16A
 Wire range: 22~12AWG 2.5mm²
 Contact Resistance: 20 mΩ
 Insulation resistance: 500MΩ/DC500V
 Withstand voltage: AC2000V / 1 min

Mechanical

Temp. Range: -40 °C ~ +105 °C
 Soldering: 250 °C 5Sec. Max.
 Torque: 0.4 N.m (3.54 Lb. in)
 Strip length: 6~7 mm

Order Information

RE - C - 128 - 7.50 - XXP - 4 S XX

RoHS
 Terminal Block
 Pitch
 No.: of Pole

Product Code: 00~99
 Screw: S- Slot Screw
 C- Cross Screw
 Color: 4- Green



NINGBO RHT ELECTRONIC CO., LTD

UNITS:mm

SHEET SIZE:A4

SCALE: ---

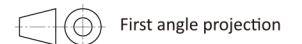

> 0~3

> 3~18

> 18~50

> 50~120

± 0.12

± 0.15

± 0.3

± 0.5

TERMINAL BLOCK

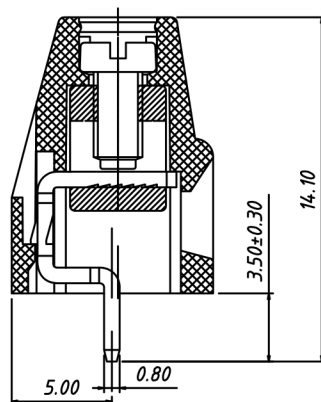
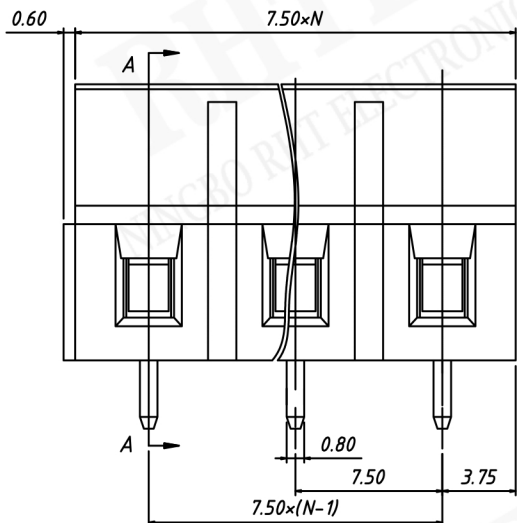
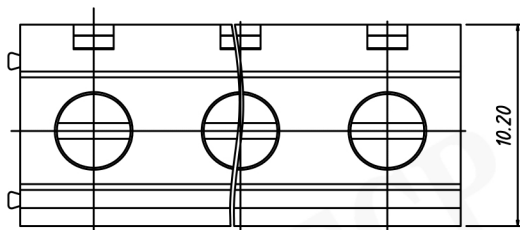

SECTION A-A

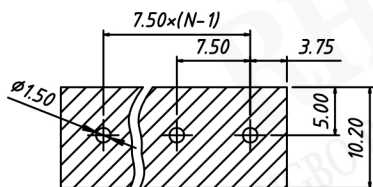

PCB LAYOUT



Material

Screw: M2.5, Steel, Zn plated
 Cage: Brass, Nickel plated
 Pin header: Brass, Tin plated
 Housing: PA66, UL94V-0

Electrical

Rated voltage: 300V
 Rated current: 16A
 Wire range: 22~12AWG 2.5mm²
 Contact Resistance: 20 mΩ
 Insulation resistance: 500MΩ/DC500V
 Withstand voltage: AC2000V / 1min

Mechanical

Temp. Range: -40 °C ~ +105 °C
 Soldering: 250 °C 5Sec. Max.
 Torque: 0.4 N.m (3.54 Lb. in)
 Strip length: 6~7 mm

Order Information

RE - C - 128 - 7.50 - XXP - 4 S XX

RoHS ————
 Terminal Block ————
 Pitch ————
 No.: of Pole ————

Product Code: 00~99
 Screw: S- Slot Screw
 C- Cross Screw
 Color: 4- Green



NINGBO RHT ELECTRONIC CO.,LTD

UNITS:mm

SHEET SIZE:A4

SCALE: ---



> 0~3

> 3~18

> 18~50

> 50~120

± 0.12

± 0.15

± 0.3

± 0.5

TERMINAL BLOCK