

### Piezo Transducer Series

RE-B-LPT-17\*04-B Without Circuit Piezo Transducer Buzzer Series

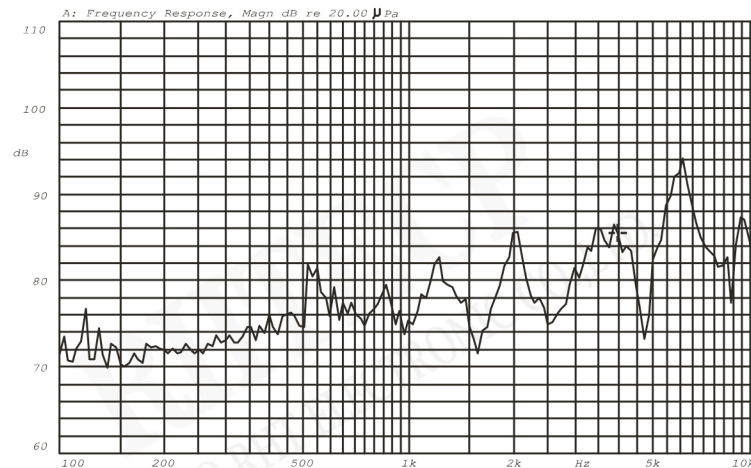

Order Code	RE-B-LPT-17*04-B
Rated Voltage	9Vp-p
Operating Voltage	3...30Vp-p
Max. Rated Current	3mA
Resonant Frequency	4±0.5KHz
Min.S.P.L. (@10cm)	80dB
Capacitance at 1,000Hz	14000±30% pF
Operating Temp	-20°C~+70°C
Weight	1.2g

### ORDER INFORMATION

Product No.: RE-B - LPT - 17\*04-B

Part Number	Order Code
Without Circuit Piezo Transducer Buzzer Series	

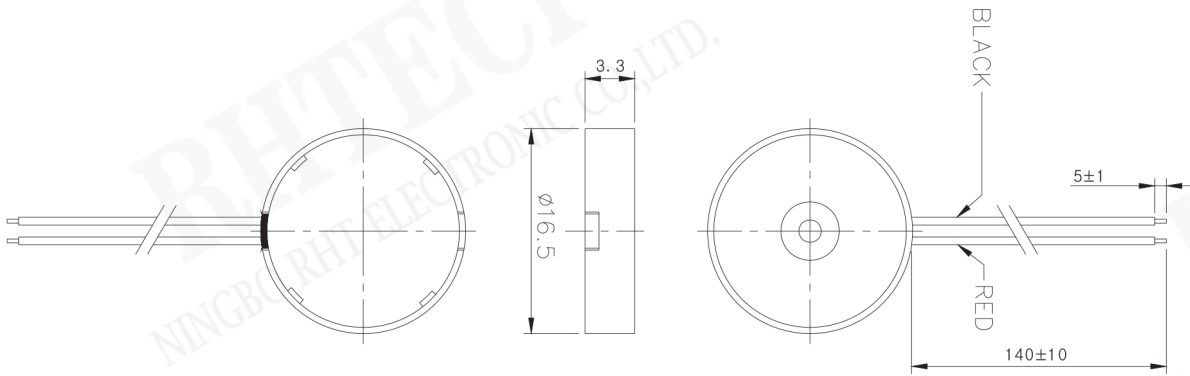

### Piezo Transducer Series

RE-B-LPT-17\*04-A Without Circuit Piezo Transducer Buzzer Series

Order Code	RE-B-LPT-17*04-A
Rated Voltage	9Vp-p
Operating Voltage	3...30Vp-p
Max. Rated Current	1.5mA
Resonant Frequency	4±0.5KHz
Min.S.P.L. (@10cm)	72dB
Capacitance at 1,000Hz	9500±30% pF
Operating Temp	-20°C~+70°C
Weight	1.2g

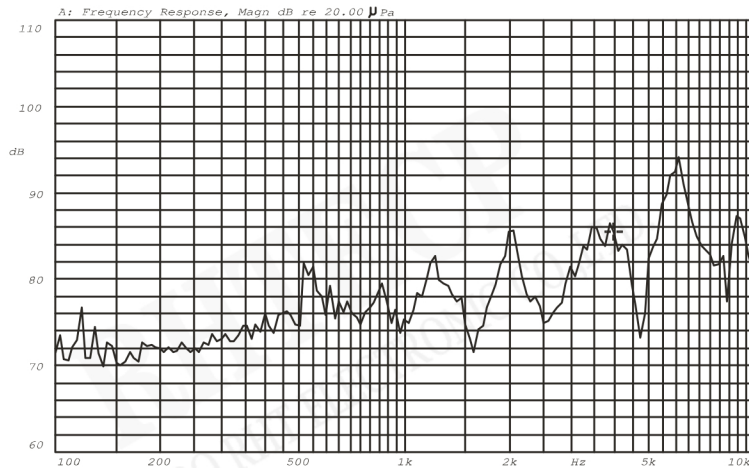

### ORDER INFORMATION

Product No.: RE-B - LPT - 17\*04-A

Part Number				Order Code
Without Circuit Piezo Transducer Buzzer Series				