

NOTE:

1.MATERIAL:

- a.HOUSING:PPA
- b.CONTACT:PHOSPHOR BRONZE
(SURFACE PLATING: Au1u")

SEE ORDERING INFORMATION

2.ELECTRIC:

- a.CONTACT RESISTANCE: 30 MILLIOHMS MAX
- b.INSULATION RESISTANCE: 1000 MEGA OHMS MIN
- c.DIELECTNIC VOLTAGE: 500V AC ONE SEC LEVEL
- d.OPERATING TEMPERATURE: -25° C~ +85° C

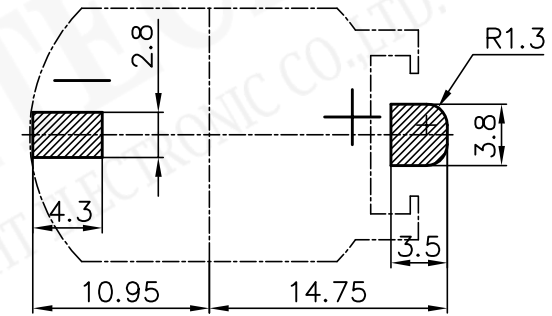
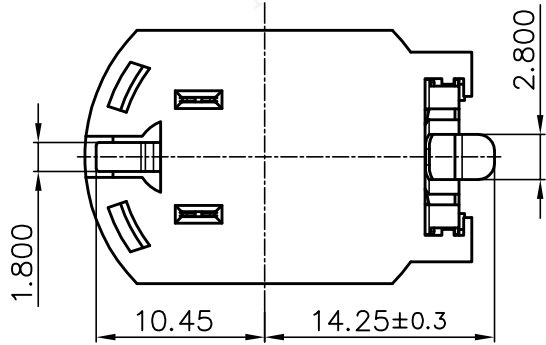
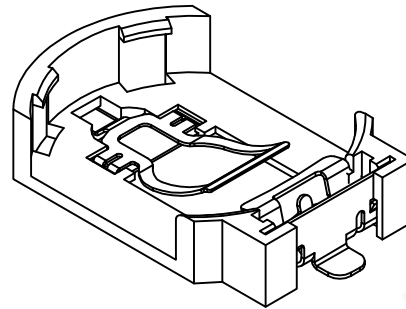
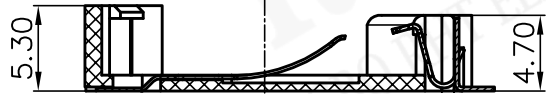

PCB Layout Diagram
Top View

③	TERMINAL(-)	1	PHOSPHOR BRONZE, T=0.20mm	Gold Plating and Ni Under-Plating
②	TERMINAL(+)	1	PHOSPHOR BRONZE, T=0.20mm	Gold Plating and Ni Under-Plating
①	HOUSING	1	PPA	BROWN
NO.	PART NAME	Q'TY	MATERIAL	PLATING & COLOR



NINGBO RHT ELECTRONIC CO., LTD

UNITS:mm

SHEET SIZE:A4

SCALE:---

RE-BH-CR2032-11-R

>0~3

>3~18

>18~50

>50~120

±0.12

±0.15

±0.3

±0.5

COIN CELL HOLERS

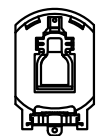

Product

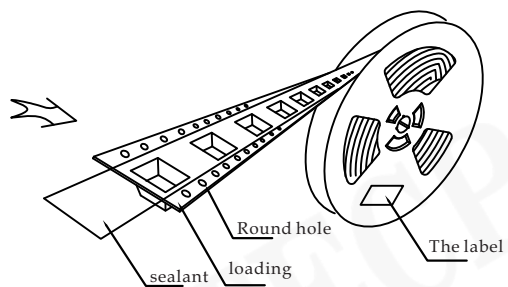

Label facing up

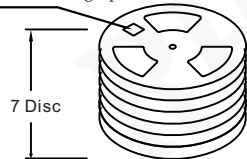

7 Disc

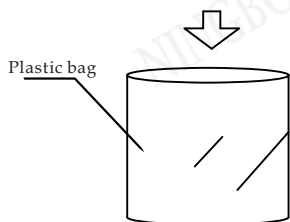

Plastic bag

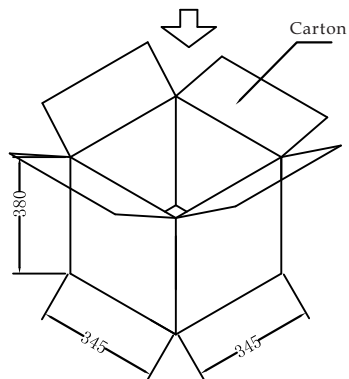

Carton

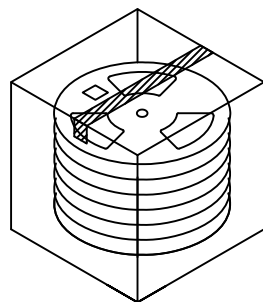

- 1、 Each reel is loaded with 500 products, and relevant labels are attached to the outside of the reel
- 2、 Put one plastic in every seven rolls
- 3、 Each outer box is packed with 6 disks. Total number of products: 3500
- 4、 The upper and lower parts of the outer box are sealed with adhesive paper into the word "work"

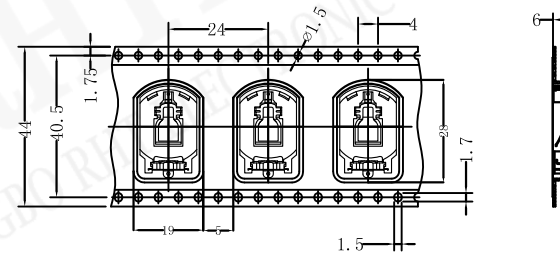
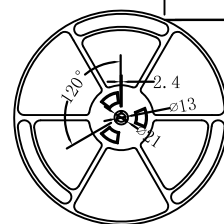
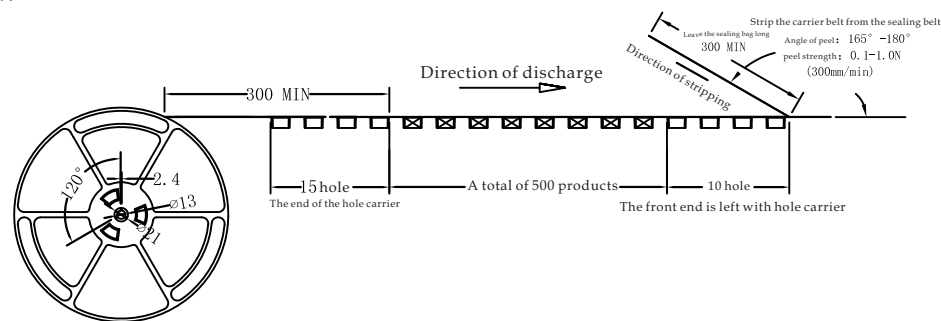
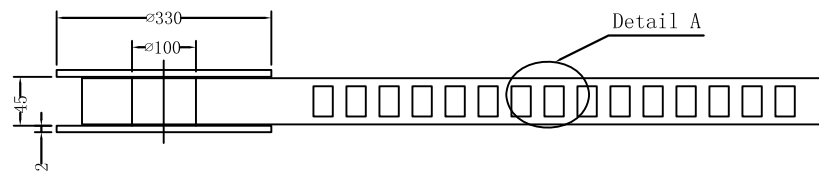

Detail A



NINGBO RHT ELECTRONIC CO.,LTD

UNITS:mm

SHEET SIZE:A4

SCALE:---

RE-BH-CR2032-11-R

>0~3

>3~18

>18~50

>50~120

±0.12

±0.15

±0.3

±0.5

COIN CELL HOLDERS